

Installation manual

Dear customer:

Congratulations on your purchase of the “Frameless Glazing System series 650”. We hope that the product meets your expectations.

The system is supplied ready to assemble. The installation is simple and the tools required are not specialised, and are readily available.

IMPORTANT: Maximum detailed information is provided within this Installation Manual in

order to avoid difficulties. For this reason, we recommend that you follow the instructions step by step.

Enlarge spaces and limitless views...



You will receive the corresponding packages and they will be clearly labeled.

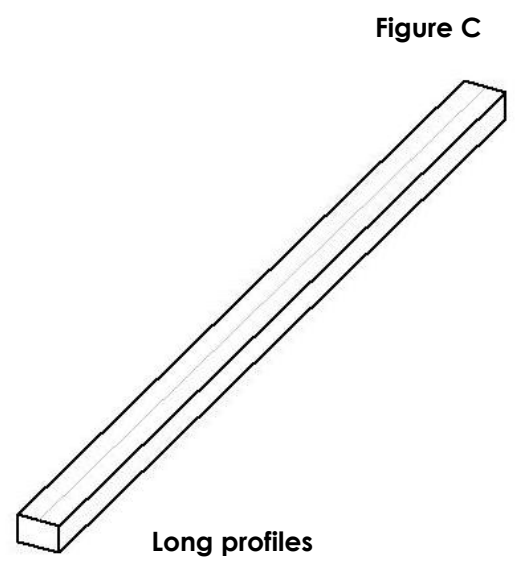
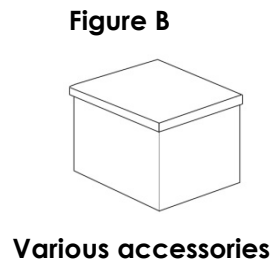
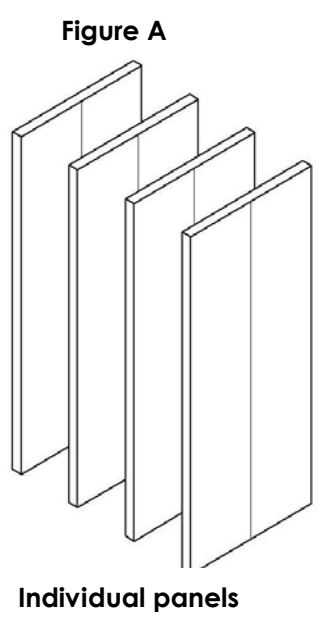
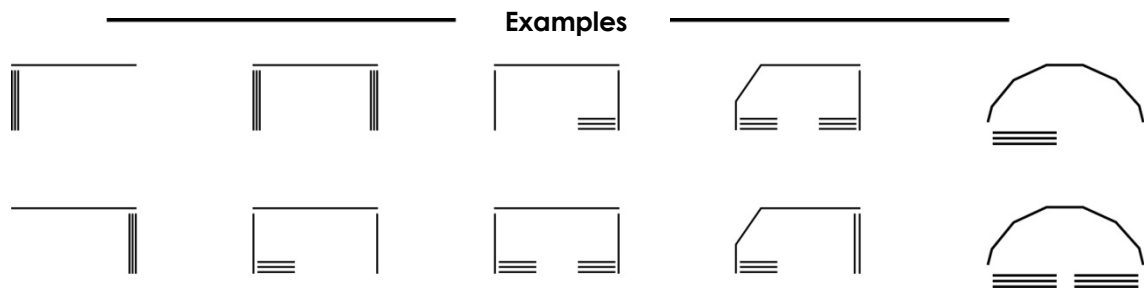

Throughout the entirety of this instruction manual, L will mean Width and H will mean height. All measurements are expressed in mm.

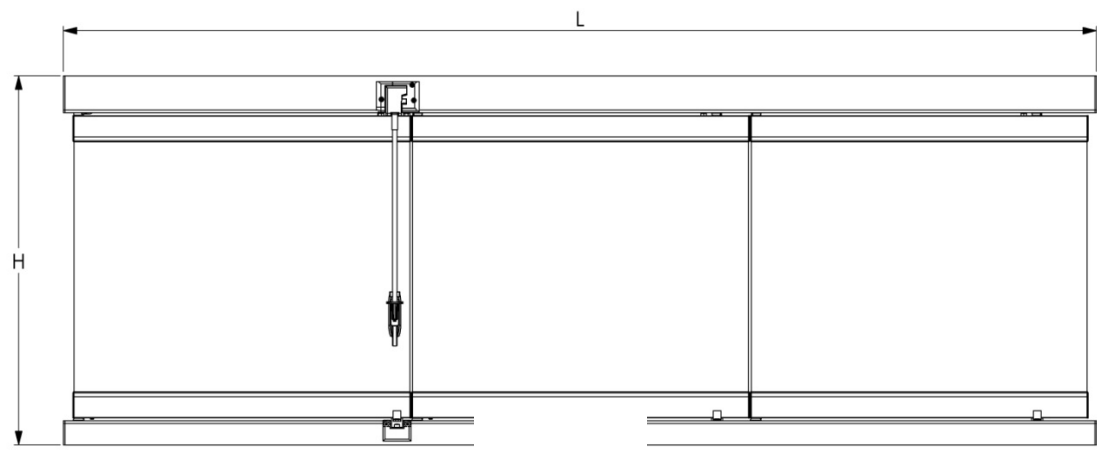

Figure D

The system basically consists of vertical glass panes and horizontal profiles.

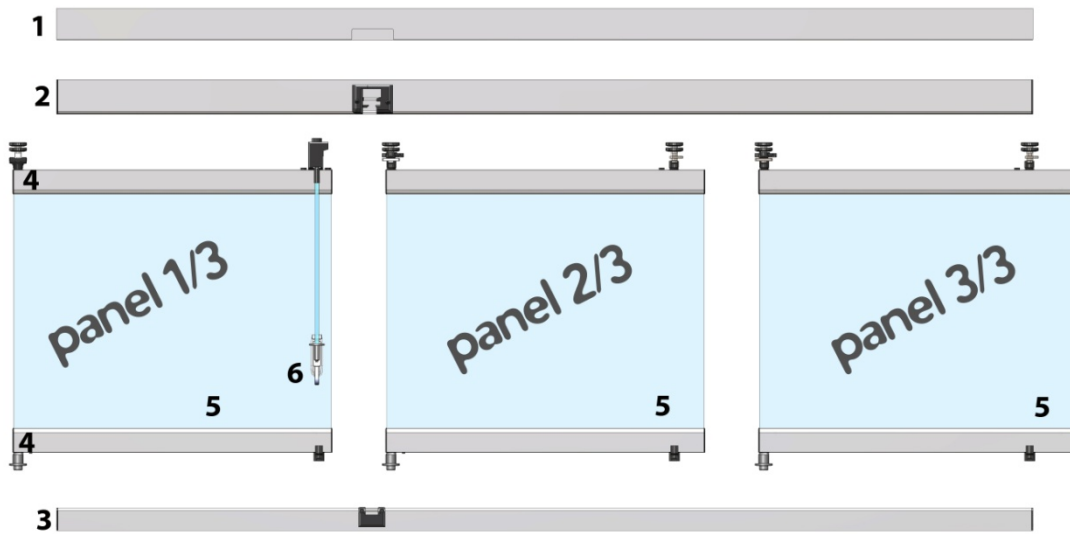

Figure E

- 1.- Top Telescopic Profile
- 2.- Upper Rail Profile
- 3.- Lower Rail Profile
- 4.- Pane Profile
- 5.- Glass thickness
6, 8 o 10 mm
- 6.-Opening Pull Ring

The enclosure can be ordered with the following versions:

Standard



Figure F

Top Telescopic



Figure G

“Top frame” Profile Assembly

The profile “Upper Rail Profile” is factory machined and provided with machined fixing holes as shown below. (Figure 1).

In addition, each section or opening pane side has a machined window to install the “Cover or Intermediate Opening Arm”. The “Opening Socket” is mounted by the opening panel side.

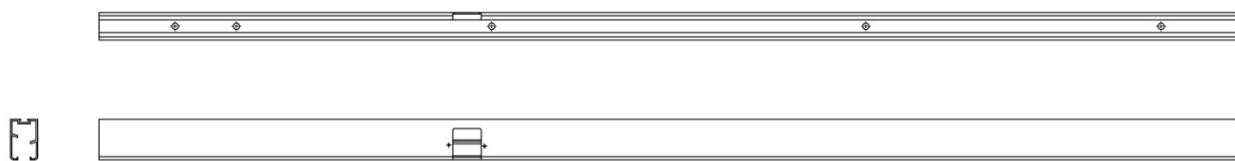

Figure 1

Assembly Process

Determine the verticality of the wall from ceiling to floor that the systems horizontal profiles will be butting against. Both upper and lower seeglass profiles should be installed vertically in line with each other. The line of verticality should be taken from the innermost point of the adjoining wall. (Figure 2)

Position the “Upper Rail Profile” at the intended mounting point and mark the drilling points on the soffit coinciding with the holes already drilled in it. (Figure 4).

Remove the “Upper Rail Profile”.

Drill holes and insert fastening plugs.

Fit and screw the “Upper Rail Profile” approximately 3-5 mm ceiling distance (Figure 5), placing the necessary compensation shims so it is perfectly levelled, both longitudinally and transversely.

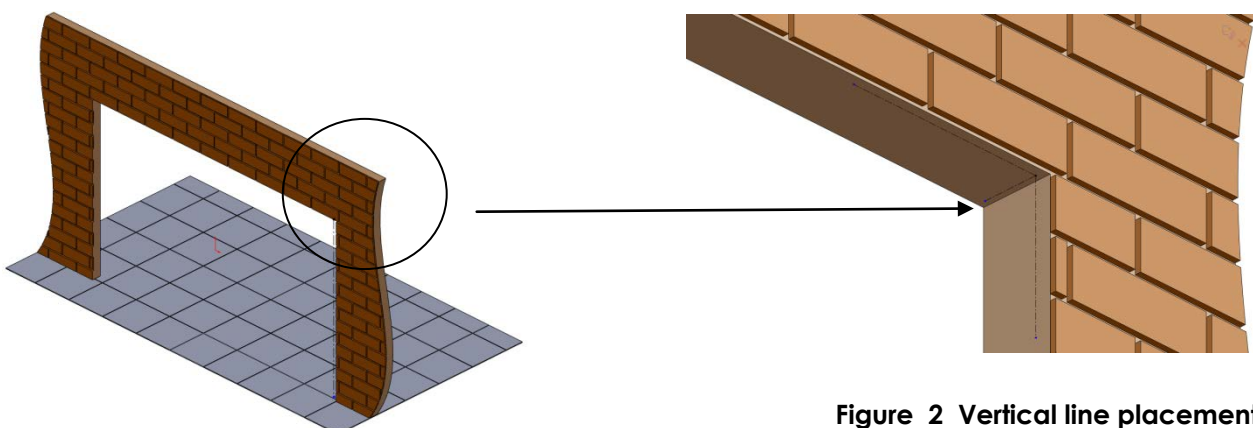

Figure 2 Vertical line placement

Figures

Figure 3

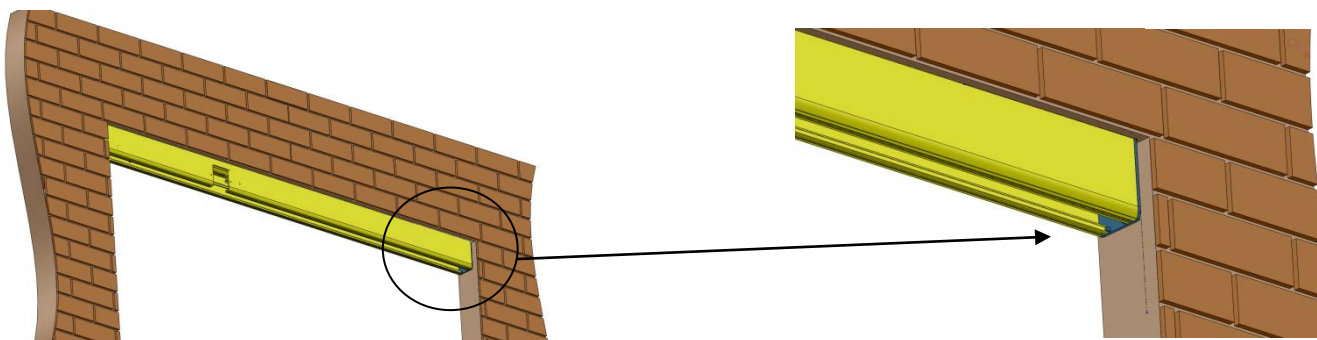

Figure 4

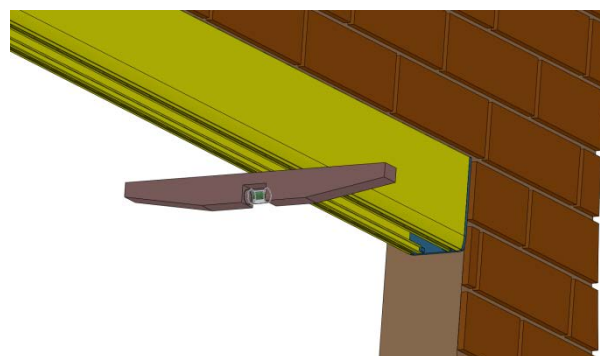
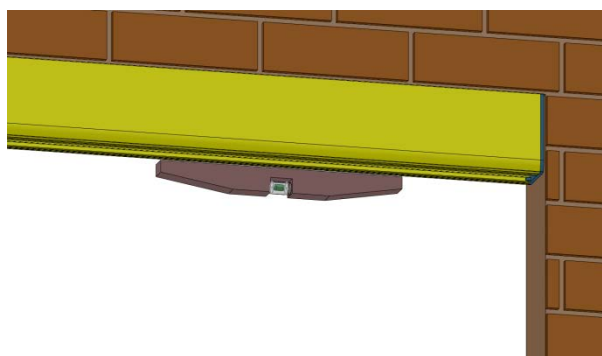

Figure 5

Model Eco

Before fixing the "Upper Rail profile", displace the "Opening Socket" (black plastic mechanism) away from the extremity of the profile (Figure 6a). Now the upper profile can be fixed. Once it is securely fixed, return the "Opening Socket" to its original position and secured in place using the fixing screw provided. (Figure 6b).

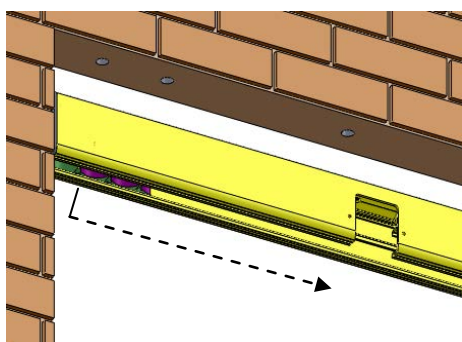

Figure 6a

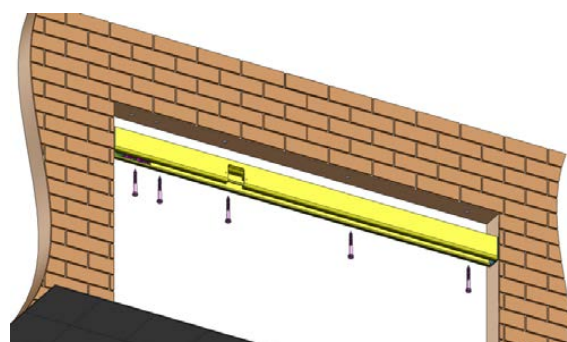
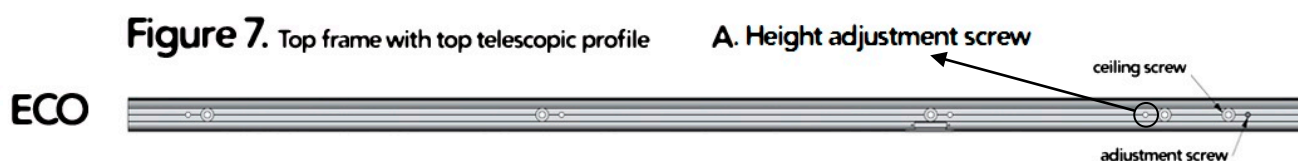

Figure 6b

“Top Telescopic Profile” Assembly

The "Top Telescopic Profile" and the "Upper Rail Profile" are pre-mounted. (Figure 7). In order to fix the "Top Telescopic Profile" to the soffit, the pre-machined holes should be used, as previously described (Figure 1). In this case, the "Upper Rail Profile" has pass through holes to fix the "Top Telescopic Profile" to ceiling.

ECO = Alignment: 1st Adjust height with screw A.



Use, adjustment and limits of Top TELESCOPIC Profile

The "Top Telescopic Profile" allows a displacement of the upper rail profile in an upwards and downwards vertical direction by means of the adjusting screws. The default label shows three reference items as given below:

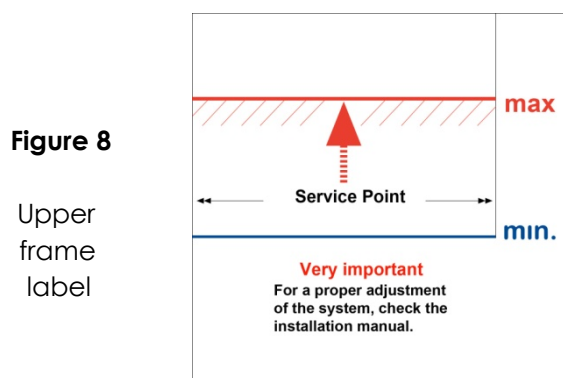

- The max. point indicates the maximum travel in a downwards direction. Do not attempt to exceed this position; it will cause disengagement of the “Top Telescopic Profile”.
- The operating point indicates the default position of the “Upper Rail Profile” with respect to the “Top Telescopic Profile during the assembly process.
- The min. point indicates the end of the travel in upwards direction.

Top Telescopic Profile Recommended use:

Adjustment	ECO	
Maximum Point	7 mm	
Minimum Point	Ceiling Panel	15 mm
		3 mm

“Lower Rail Profile” Assembly

The “Lower Rail profile” is factory machined (Figure 11) with holes following the same scheme (Figure 1) of “Upper Rail Frame”.

Furthermore, the window to install the “Intermediate Opening Arm” is machined in all sections or opening panes. The hinge-base components for rotating and “Blocking Opening Panels” are pre-assembled without blocking the rail hinge.

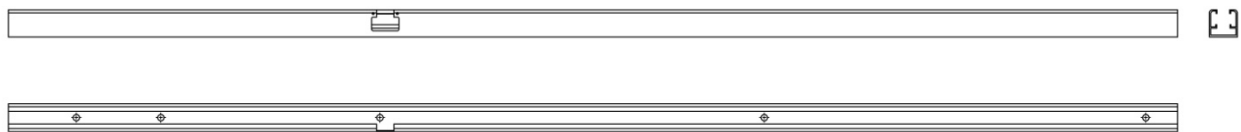

Figure 11

Assembly Process

Place the “Lower Rail Profile” at the mounting point and line, exactly under the vertical line of the “Upper Rail Profile” (Figure 12).

Mark the drilling points on the floor coinciding with the holes already drilled in there.

Remove the “Lower Rail Profile”. Drill the holes and insert the fasten plugs.

Fit and screw the “Lower Rail Profile” about 3-5 mm floor distance (figure 14), placing the necessary compensation shims so it is perfectly and horizontally levelled, both longitudinally and transversely (Figure 15).

Verify the distance and parallelism between “Top and Lower Rail Profile”.

- ECO Measure: Free height between Frames = panels height (without components) + 10mm

Figures

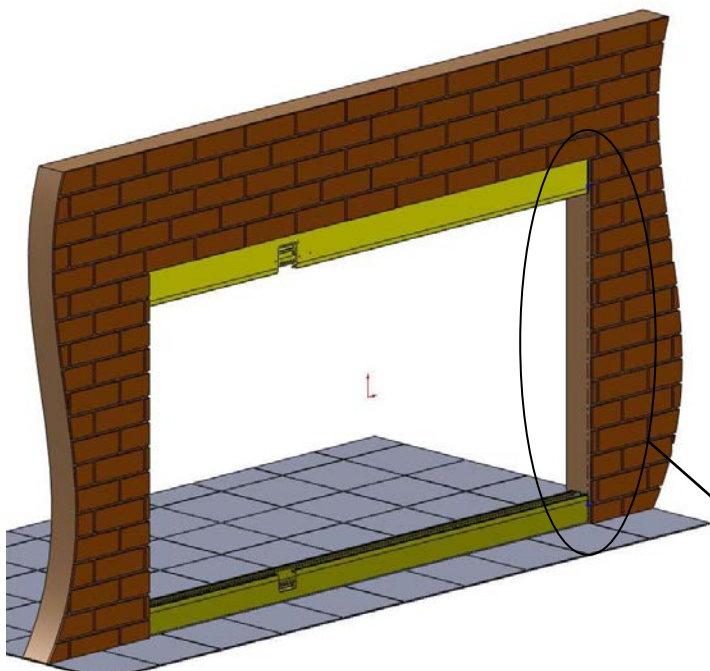

Figure 12

Figure 13

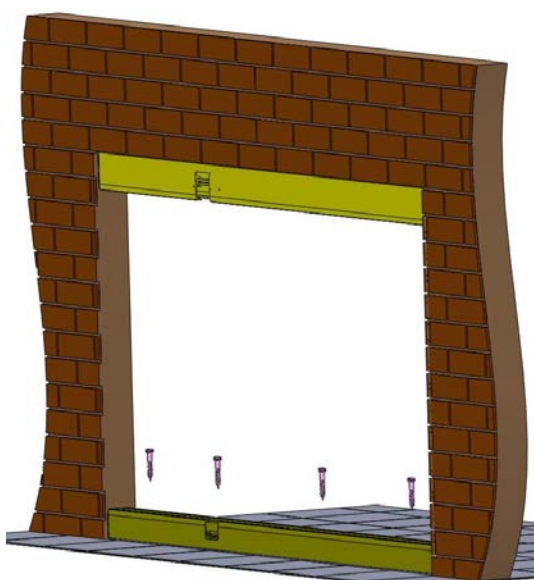
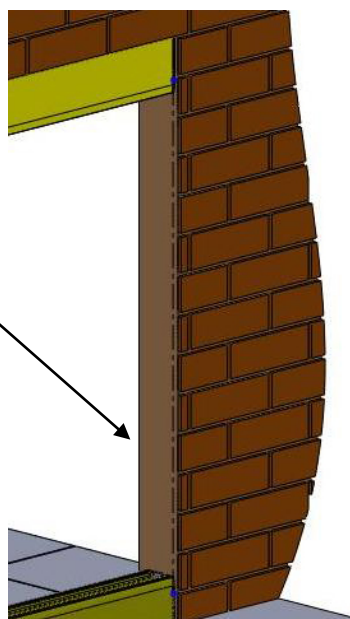

Figure 14

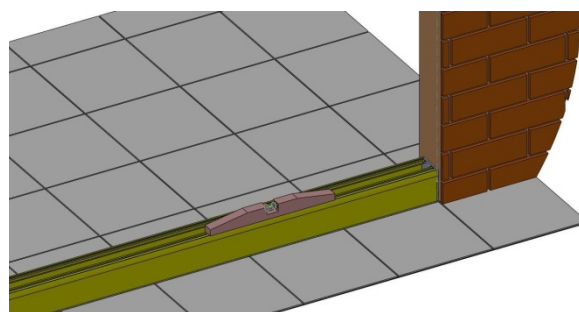

Figure 15

“Panels” Assembly

Panels are assembled in “Lower and Top Rail Profile” and always before fixing the components for the opening panes. They are always numbered depending on its exacting mounting position. Each 1st section pane is always fixed on the side / end / opening point.

Mounting Process (First Panel)

Enter the 1st panel through the two exit windows of “Lower and Top Rail Profiles” by the section that has the mounted bearing hinge towards the opening end/point. The panel must be positioned as far parallel as possible to the frames. (Figure 19).

During the introduction process, the locking pin must be 90° with respect to “Upper Rail Profile” (Figure 20) always against the “Upper Rail Profile” opening side. At the same time, the cap clip must be inserted and longitudinally aligned with the profile, as seen. (Figure 20)

Slide the 1st panel to the opening end/point (1st, opening socket position) and then secure it by rotating the locking pin 90° into the profile) (Figure 21).

Adjust the position of the carriage/hinge-base guide track of the “Lower Rail Profile” slightly, if necessary, to leave the 1st panel in perfect vertical position and leveled. (Figure 22).

Once it is leveled, fix the carriage/hinge-base guide track of the “Lower Rail Profile” by fixing the set screws completely.

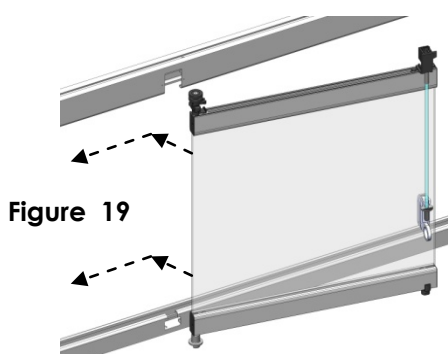

Figure 19

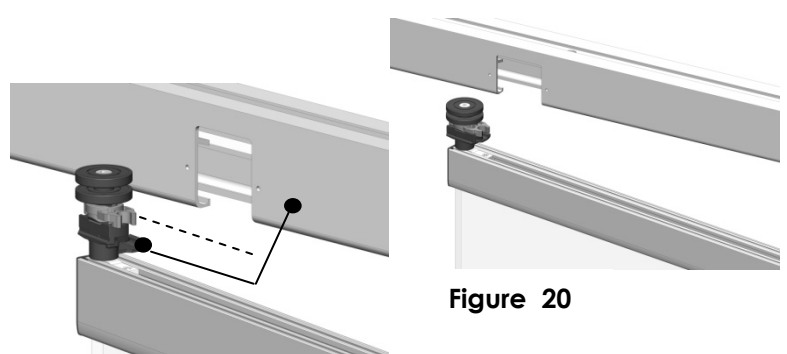

Figure 20

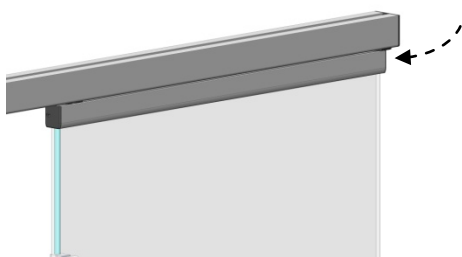
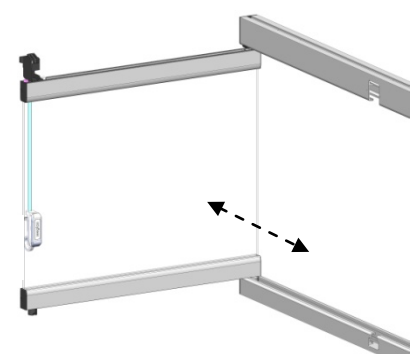

Figure 21 rotate the locking pin 90°

Figure 22



“Panels” Assembly

Mounting Process (Remaining Panels)

Enter the remaining panes through the two exit windows of “Upper and Lower Rail Profiles” contrary to the end / opening point where the carriage hinge and the opening stopper is mounted. (Figure 23)

The order of introduction of panels is inverse, 1st insert last panel (the highest numbered and so on until the last one).

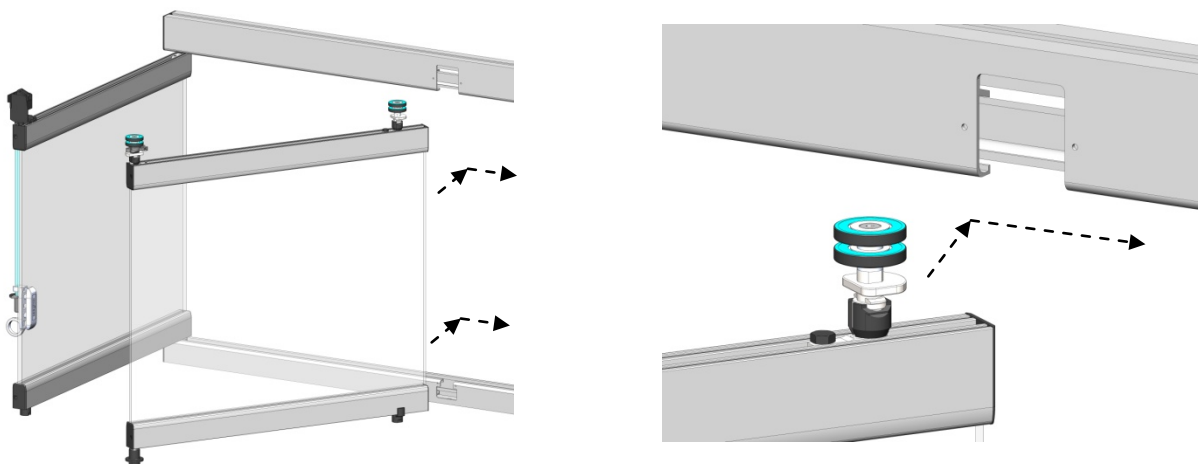
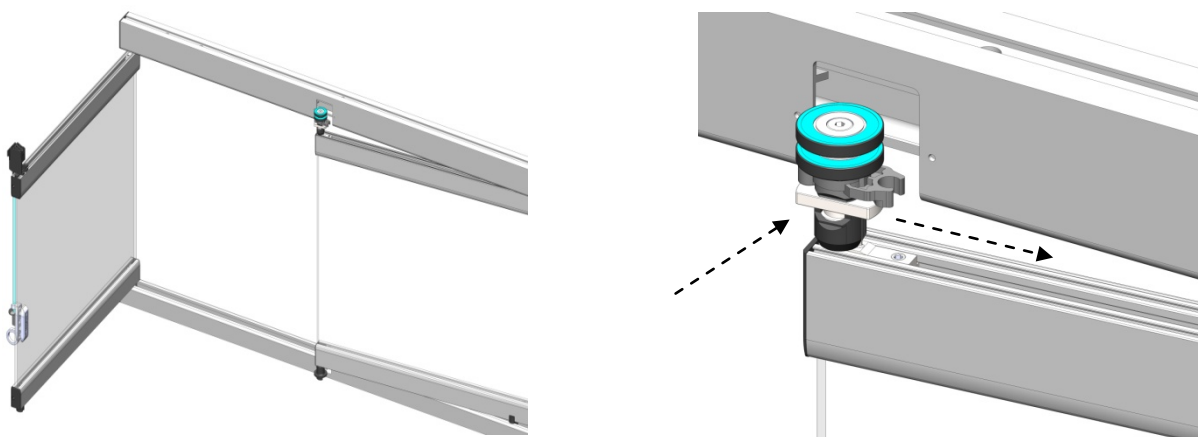

Figure 23 Enter 2nd panel



1st Panel Assembly with Lateral Profiles

Place the locking pin outside facing and take it up to 2nd position. Turn it inward and lead it to the end and insert it in the profile.

Lower Embedded Profile Assembly MODEL ECO

Mounting Process

Start the installation entering 1st panel lower hinge through the machined opening of the “Lower Embedded Profile” (Figure 24) keeping the upper carriage/hinge as close as possible to the “Upper Rail Profile”. (Figure 25).

In this position, insert the pane through to the machined opening of the “Upper Rail Profile” and taking into consideration that the cap clip must be introduced and longitudinally aligned with the “Upper Rail Profile”. (Figure 26).

Repeat above steps as many times as panels take the enclosure. (Figure 27)

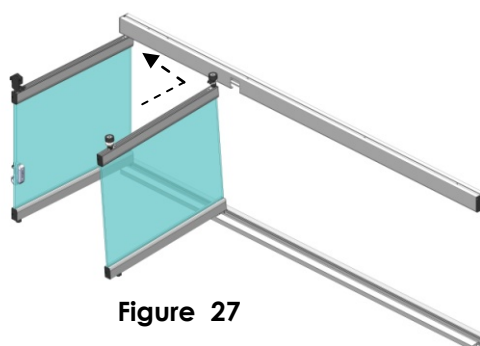
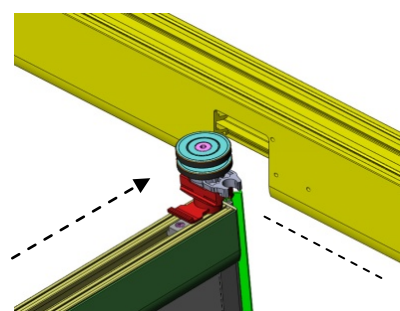
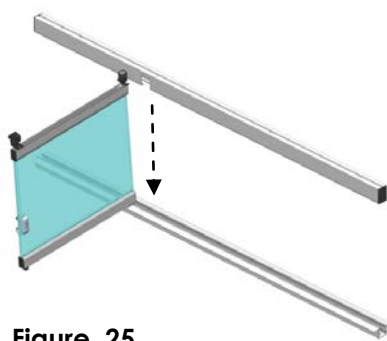
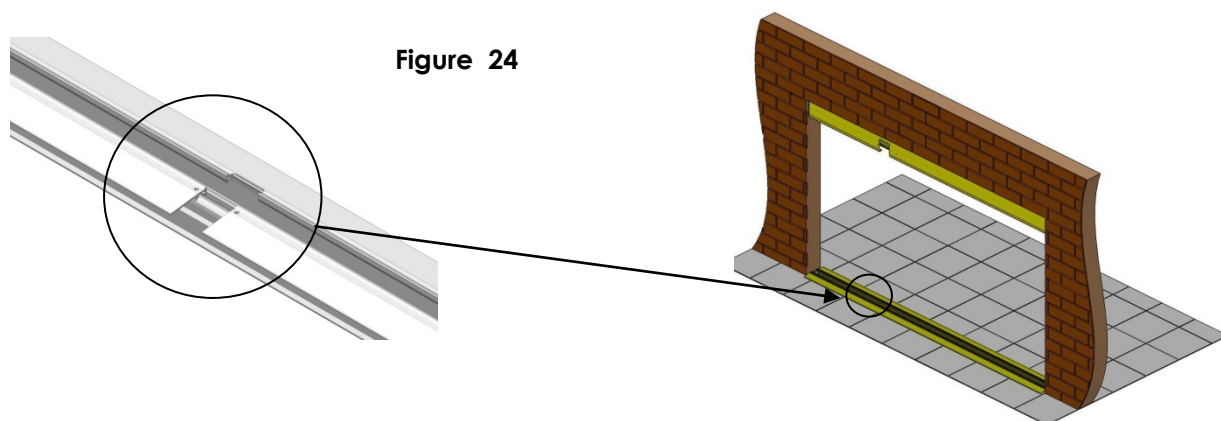

“Opening Parts” Assembly

Mounting Process

Enter the “Opening Cap Lower Rail” in its housing and screw it to the “Lower Rail Profile” with two screws. (Figure 30)

Enter the “Opening Arm Cap” in the middle of the “Upper Rail Profile” window and fix it with screws. (Figure 30)

Figure 30
Cap Assembly
Top and Lower
Exit Panels

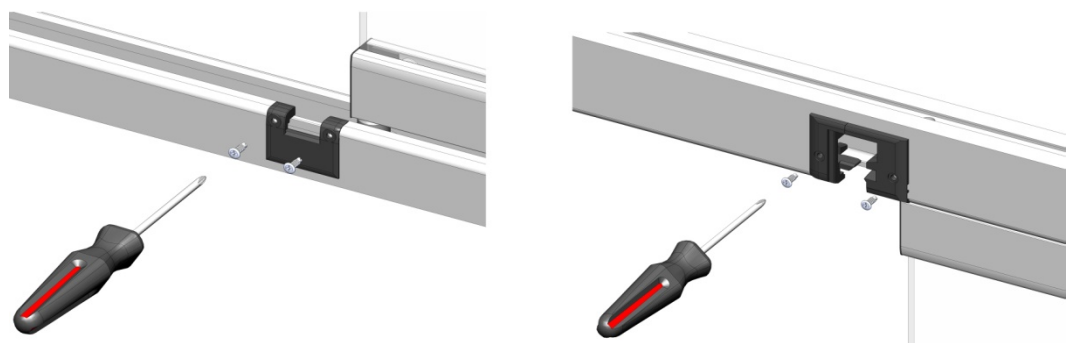

Accessories and Variations

Use of the Wall Fixing Clamp

Fasten the wall support with the corresponding screw as well as the holding tape. (Figure 34)

The other end of "Wall Fixing Clamp Kit" will be used to fasten the last opened panel and then the holding tape must be tightened to secure all panels. (Figure 36)

To release the panes, the holding tape must be loosened by pressing the lock flange. (Figure 35).

Please use the wall support to place the fixing clamp when the enclosure is closed. (Figure 37)

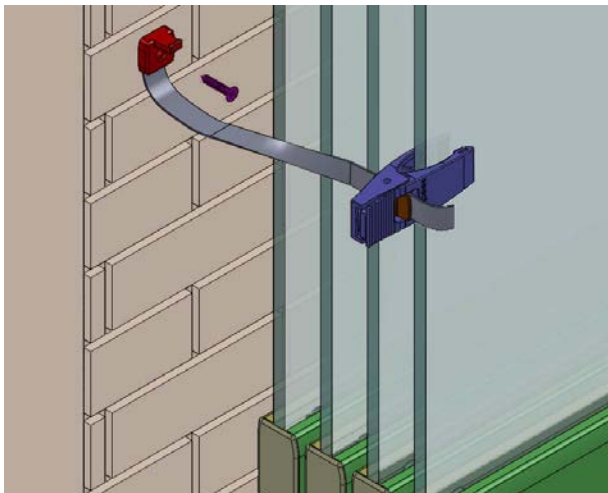

Figure 34

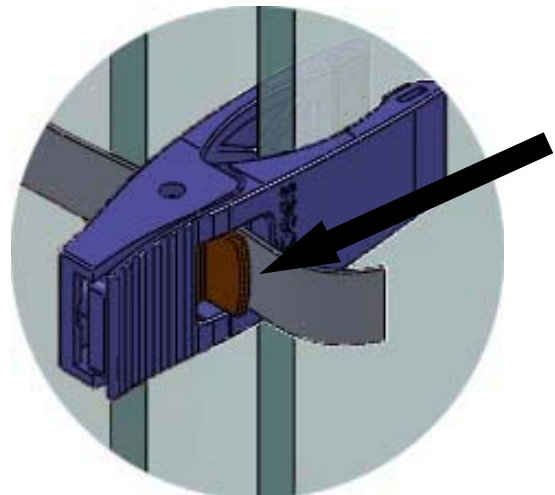

Figure 35

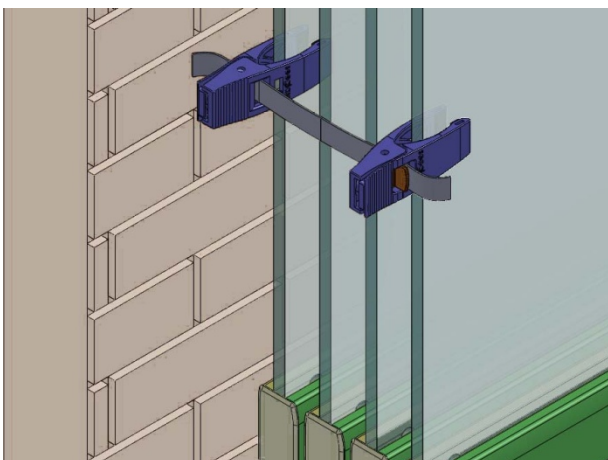

Figure 36

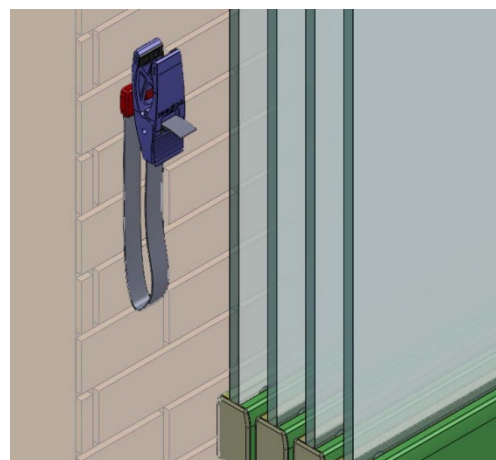
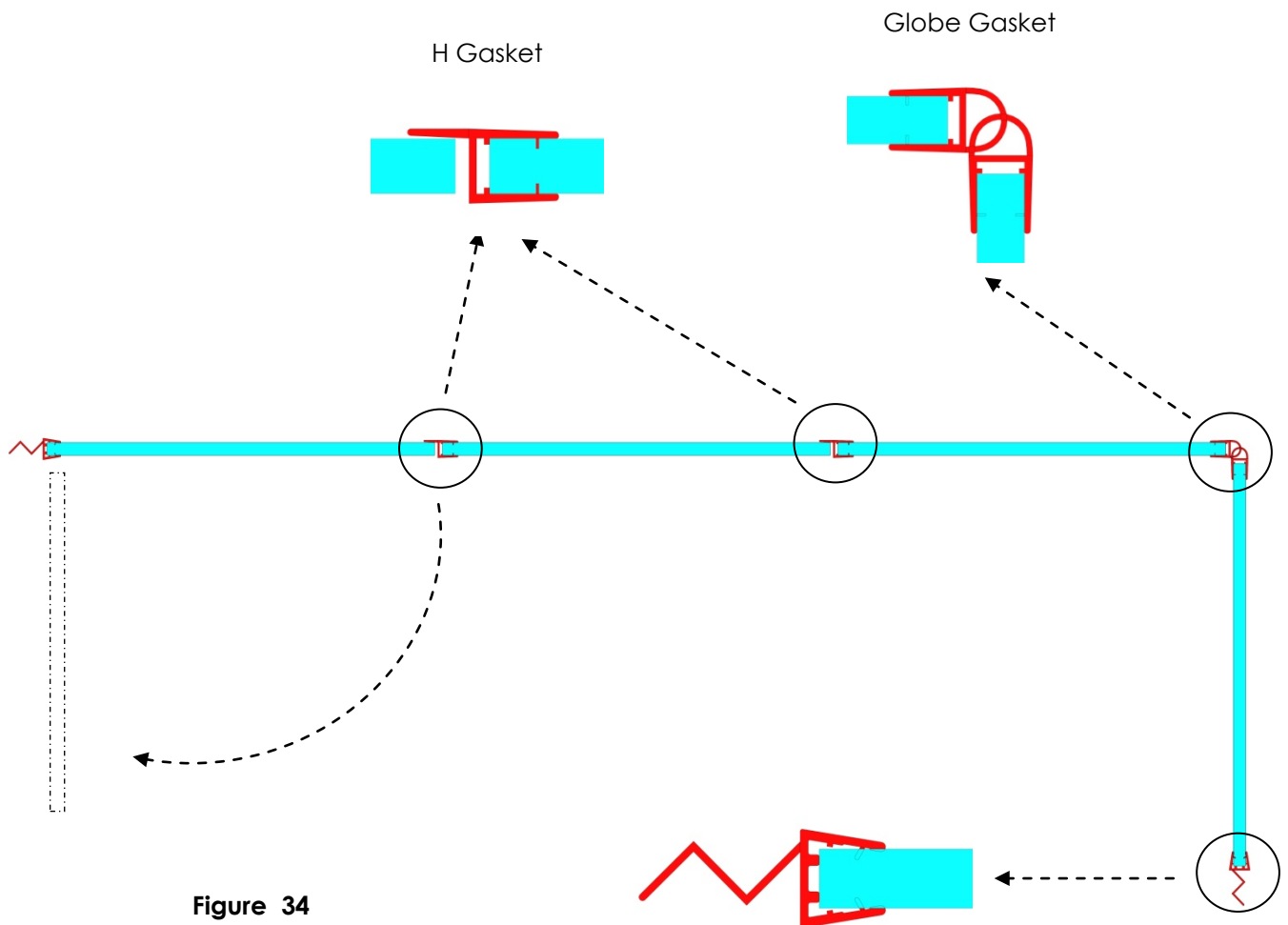

Figure 37

Gaskets



Wall End Rubber Gaskets are assembled at the wall ends.

“H” Gaskets are assembled between panels in straight sections. Globe Gaskets are assembled in angle junctions.

Recommendations

Installation:

- Seal the holes of Lower Rail Profile to prevent leaks.
- Lubricate the system only with silicon spray.
- Allow 5mm between panel profile and upper rail profile.
- While installing and regulating the lock, open the panels holding them from falling until they are adjusted.

Use:

- Do not clean the glass and profiles with corrosive products containing alcohol, bleach or ammonia. The combination with sun burns the joints and eliminates the gloss coatings.
- Lubricate the system only with silicon spray.
- The inside of lower profiles must be cleaned and free from objects.

Resolution of incidences

Problem	Cause	Solution
Lifting Panels	The exit taps in top/lower rail have not been assembled.	Complete the adjustment and place the exit taps.
	Wrong adjustment of the plus system and/or exit carriage hinge in the window.	Check the positioning of plus parts in profile/panels and the exit carriage hinge.
	Upper Rail Opening Socket and the base of lower profile are not aligned.	Check that the upper and lower hinge reach at the same time.
	Frames are not properly aligned or levelled.	Check and adjust.
	First Clip Hinge is reverse.	Remove the panel, turn the clip and re-enter again.
Panels do not open	Wrong adjustment of carriage hinges.	Adjust exit carriage hinges.
PLUS components do not work	The top rail is warped or uneven.	Adjust and ensure the proper installation of upper rail profile.

Enlarge spaces and
limitless views...